

App Note 3426: Resistive Bridge Basics: Part One

Bridge circuits are a time-honored way to make accurate measurement of resistance and other analog values. This article covers the basics of bridge circuits and shows how to use them to make accurate measurements in practical environments. It details the key concerns of bridge-circuit applications such as noise, offset voltages and offset voltage drift, common-mode voltage, and excitation voltage. It describes how to interface bridges to high-resolution, analog-to-digital converters (ADCs) and the techniques for maximizing ADC capabilities.

Introduction

The Wheatstone bridge was developed in the early days of electronics as a way to accurately measure the value of resistors without needing an accurate voltage reference or a high-impedance meter. Although resistive bridges are seldom used for this original purpose, they are still widely used in sensor applications. This article will show why bridges are still so popular and discuss some key considerations in measuring the output of a bridge.

NOTE: This is a two-part article. Part one reviews the basic bridge and focuses on bridges with low output signals, like those from bonded-wire or bonded-foil strain gauges. Part two, [Application Note 3545](#), addresses high output bridges like those that use silicon resistors.

Basic Bridge Configurations

Figure 1 is a classic Wheatstone bridge in which the bridge output, V_o , is the differential voltage between V_{o+} and V_{o-} . When used in a sensor, the value of one or more of the resistors will change with the intensity of the property being measured. These changes in resistance cause the output voltage to change. Equation 1 shows the output voltage, V_o , as a function of the excitation voltage and all the resistors in the bridge.

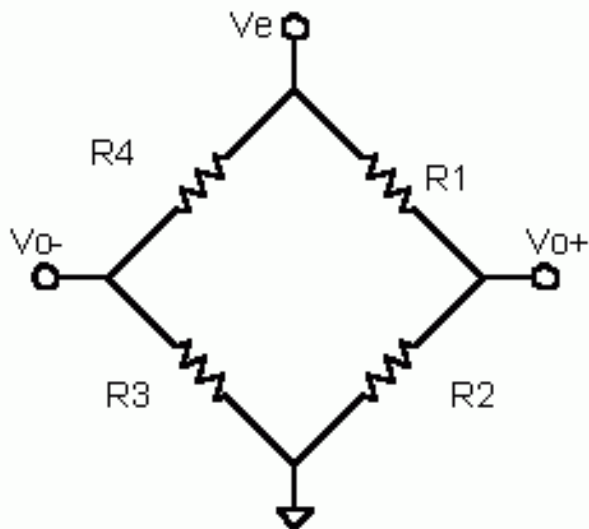

Figure 1. Diagram of a Basic Wheatstone Bridge.

$$\text{Equation 1: } V_o = V_e \left(\frac{R_2}{R_1 + R_2} - \frac{R_3}{R_3 + R_4} \right)$$

Equation 1 is not elegant, but can be simplified for most bridges in common use. Bridge outputs are the most sensitive to changes in resistance when V_{o+} and V_{o-} equal $1/2$ of V_e . This condition is easily achieved by using the same nominal value, R , for all four resistors. Resistance variations caused by the property being measured are accounted for by a ΔR or dR term. Resistors with a dR term are cited as "active" resistors. In the following four cases, all the resistors have the same nominal value, R . One, two, or four of the resistors will be active, or have a dR term. In deriving these equations, dR is assumed to be positive. If the resistance actually decreases, then $-dR$ used. In the special cases below, the magnitude of dR is the same for all active resistors.

Four Active Elements

In the first case, all four bridge resistors are active. The resistance of R_2 and R_4 increase with the intensity of the property being measured, while the resistance of R_1 and R_3 decreases. This case is typical of a load cell using four strain gauges. The physical orientation of the strain gauges determines whether their value will increase or decrease when a load is applied. Equation 2 shows that this configuration produces a simple linear relationship between the output voltage (V_o) and the change in resistance (dR). This configuration also provides the largest output signal. It is worth noting that the output is not just a linear function of dR , it is a linear function for dR/R . This is a subtle but important difference because the change in resistance of most sensing elements is proportional to their bulk resistance.

$$\text{Equation 2: } V_o = V_e \cdot \left(\frac{dR}{R} \right) \text{ A bridge with four active elements.}$$

One Active Element

The second case is a single active element (Equation 3). This is frequently used when cost or wiring considerations are more important than the signal's amplitude.

$$\text{Equation 3: } V_o = V_e \cdot \left(\frac{dR}{4 \cdot R + 2 \cdot dR} \right) \text{ A bridge with one active element.}$$

As might be expected, the bridge with one active element has $1/4$ as much output signal as the bridge with four active elements. Another important characteristic of this configuration is the nonlinear output caused by the addition of a dR term in the denominator. This nonlinearity is small and

predictable. If necessary, it can be corrected in software.

Two Active Elements with Opposite Response

The third case, shown in Equation 4, has two active elements with resistances that change in opposite directions (dR and $-dR$). Both resistors are placed on the same side of the bridge ($R1$ and $R2$, or $R3$ and $R4$). As expected, the sensitivity is twice that of the bridge with a single active element, and half that of the bridge with four active elements. The output for this configuration is a linear function of dR and dR/R . There are no dR terms in the denominator.

Equation 4: $V_o = V_e \cdot (dR/(2 \cdot R))$ Two active elements with opposite response.

In both the second and third cases above, only half of the bridge is active. The other half simply provides a reference voltage that is $1/2$ of V_e . Consequently, it is not actually necessary for all four resistors to have the same nominal value. It is only important that both resistors on the left half of the bridge match and both resistors on the right half of the bridge match.

Two Identical Active Elements

The fourth case also uses two active elements, but these elements have a like response—they both increase in value or decrease in value. To be effective, these resistors must be at diagonals in the bridge ($R1$ and $R3$, or $R2$ and $R4$). The obvious advantage to this configuration is that the same type of sensing element can be used in both locations. The disadvantage is the nonlinear output resulting from the dR term in the denominator of Equation 5.

Equation 5: $V_o = V_e \cdot (dR/(2 \cdot R + dR))$ Two identical active elements in a voltage-driven bridge.

This nonlinearity is predictable, and can be removed with software or eliminated by driving the bridge with a current source rather than a voltage source. In Equation 6, I_e is the excitation current. It should be noted that V_o in Equation 6 is only a function of dR , not the ratio of dR/R as it was in the prior cases

Equation 6: $V_o = I_e \cdot (dR/2)$ Two identical active elements in a current driven bridge

Understanding the four special cases above is useful when working with individual sensing elements. Many times, however, the sensor has an internal bridge with an unknown configuration. In these instances, knowing the exact configuration is not really important. The manufacturer will supply the necessary information, like sensitivity linearity error, common-mode voltage, etc. But why use a bridge in the first place? This question is easily answered by looking at the following example.

Load-Cell Example

One common example of a resistive bridge is a load cell with four active elements. Four strain gauges are arranged in a bridge configuration and bonded to a rigid structure that deforms slightly when a load is applied. As the load is applied, the value of two strain gauges increases while the value of the other two strain gauges decreases. These changes in resistance are very small. The full-scale output of a typical load cell is 2mV per volt of excitation. From Equation 2 we can see that this is equivalent to a full-scale change in resistance of only 0.2% . If the output of the load cell must be measured to an accuracy of 12-bits, then changes in resistance of $1/2\text{ppm}$ must be accurately measured. Measuring $1/2\text{ppm}$ changes directly would require a 21-bit ADC. Besides needing a very

high-resolution ADC, the ADC reference would need to be ultra stable. It could not change more than 1/2ppm over temperature. These two reasons provide enough motivation for using a bridge, but there is an even better reason.

The resistors in the load cell respond to more than just the applied load. Thermal expansion of the structure to which they are bonded and the TCR of the gauge material itself will cause resistance changes. These unwanted changes in resistance can be as large, or larger, than the change due to intended strain. If, however, these undesirable changes occur equally in all the bridge resistors, then their effect is negligible or nonexistent. An unwanted change of 200ppm, for instance, is equivalent to 10% of full scale in this example. But in Equation 2, changing R by 200ppm creates less than 1LSB of difference on a 12-bit measurement. In many cases, the wanted change in resistance, dR , is directly proportional to the bulk resistance, R. In these cases, changing R by 200ppm should have no effect because the ratio of dR/R remains the same. The value of R could double and the output voltage would not be affected because dR would also double.

The above example shows how using a bridge can ease the task of measuring very small changes in resistance. The following section covers the major circuit concerns when measuring a bridge.

Five Key Concerns in Bridge Circuits

There are many considerations when measuring low-output bridges. Five of the most important concerns are:

1. Excitation voltage
2. Common-mode voltage
3. Offset voltage
4. Offset drift
5. Noise

Excitation Voltage

Equation 1 shows that the output of any bridge is directly proportional to its supply voltage. Therefore, the circuit must either hold the supply voltage constant to the same accuracy as the desired measurement, or it must compensate for changes in the supply voltage. The simplest way to compensate for supply-voltage changes is to derive the ADC's reference voltage from the bridge's excitation. In Figure 2 the ADC's reference voltage comes from a voltage divider placed in parallel with the bridge. This causes changes in supply voltage to be rejected, because the ADC's voltage resolution will change along with the bridge's sensitivity.

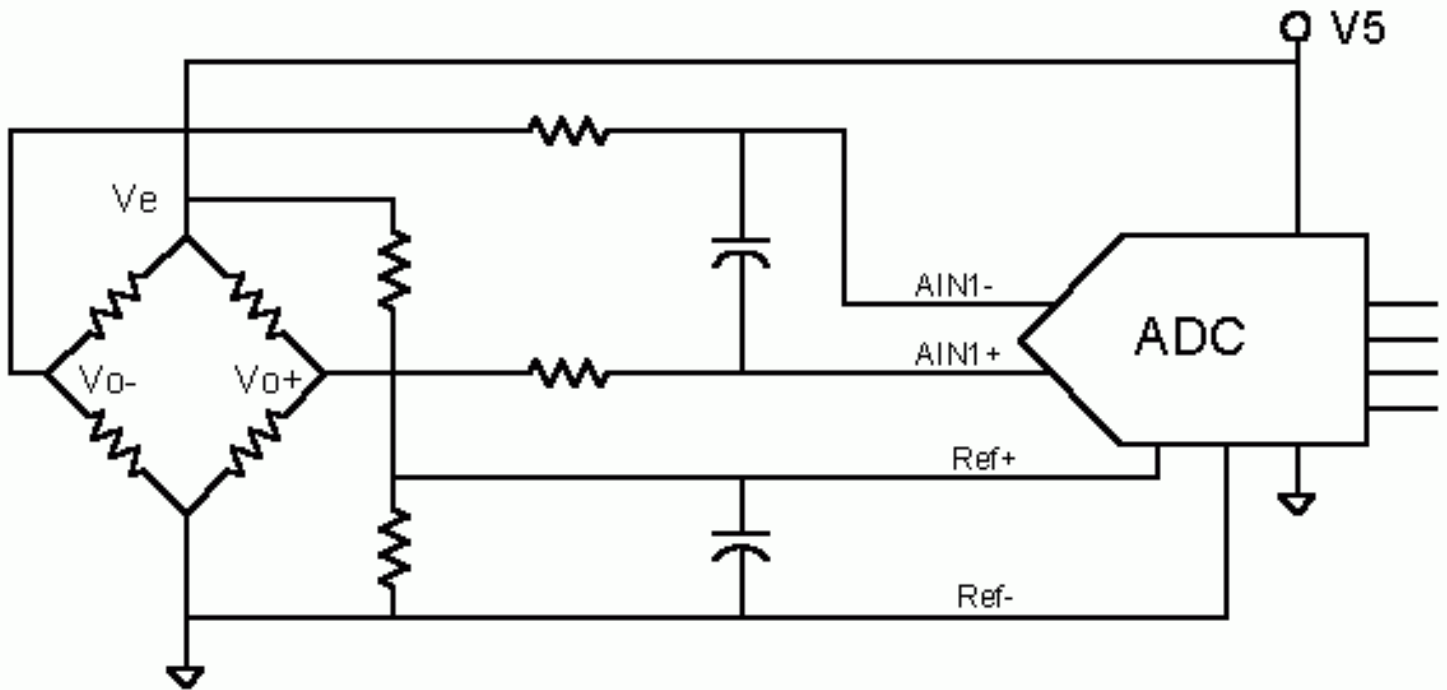

Figure 2
The reference voltage for the ADC is proportional to V_e .
This eliminates gain errors due to changes in V_e .

An alternate approach uses an additional input channel on the ADC to measure the bridge's excitation voltage. Software can then compensate for changes in bridge voltage. Equation 7 shows the corrected output voltage, (V_{oc}), as a function of the measured output voltage (V_{om}), the measured excitation voltage (V_{em}), and the excitation voltage at the time of calibration (V_{eo}).

Equation 7: $V_{oc} = V_{om} \cdot V_{eo} / V_{em}$

Common-Mode Voltage

One drawback of the bridge is that the output is a differential signal with a common-mode voltage equal to half the supply voltage. Often this differential signal must be level-shifted and converted to a ground-referenced signal before going to the ADC. If this is necessary, pay close attention to the common-mode rejection of the system and how the common-mode voltage is affected by changes in V_e . Returning to the load cell example above, consider the effects of a change in V_e , if an instrumentation amplifier is used to convert the differential signal from the bridge to a single-ended signal. If V_e is allowed to change by 2%, the common mode-voltage at the bridge's output will change by 1% of V_e . If the affect of this common-mode shift is limited to 1/4 of the accuracy spec, then the amplifier must have a common-mode rejection of 98.3 dB or better.

$(20 \cdot \log[0.01 \cdot V_e / (.002 \cdot V_e / (4096 \cdot 4))]) = 98.27$). This level of performance is certainly achievable, but is beyond the range of many low-cost or discrete instrumentation amplifiers.

Offset Voltage

Offsets from both the bridge and the measurement electronics shift the desired signal up or down. Compensating for these shifts is easy during calibration, as long as the signal remains within the active range of the electronics. If the differential bridge signal is being converted to a ground-referenced signal, the offset of the bridge and amplifiers can easily create a signal that is theoretically below ground. When this happens, it creates a dead spot. The ADC's output remains railed at zero

until the bridge's output signal becomes positive enough to overcome all the negative offsets in the system. To prevent this, an intentional positive offset must be designed into the circuit. This offset ensures that the output will be in the active range, even if the bridge and the electronics have negative offsets. A lesser problem with offset is the reduction of dynamic range. If this occurs, then higher quality components or electronic offset adjustments may be needed. Adjustment of the offset may be done with mechanical pots, digital pots, or even by connecting resistors to the GPIO bits on the ADC.

Offset Drift of the Electronics

Offset drift and noise are by far the largest problems associated with bridge circuits. In the load-cell example above, the full-scale output of the bridge is 2mV/V and the desired accuracy is 12-bit. If the load cell is powered from a 5V supply, then the full-scale output will be 10mV and the measurement accuracy must be $2.5\mu\text{V}$ or better. Restated simply, an offset shift of only $2.5\mu\text{V}$ will create an error of 1LSB at the 12-bit level. This is a challenging requirement for high-quality conventional op-amps. The OP07, for example, has a max offset TC of $1.3\mu\text{V/C}$ and a maximum long-term drift of $1.5\mu\text{V}$ per month. To maintain the very low offset drift needed for bridges, some type of active offset adjustment is needed. This can be done in hardware, software, or a combination of both.

Hardware-based offset adjustment: Chopper stabilized or auto-zeroing amplifiers represent a pure hardware solution. Integrated into the amplifier is a special circuit that continually samples the input and adjusts to maintain a minimal difference in the voltage between the input pins. As these adjustments are continual, drift over time and temperature becomes a function of the correction circuit and not the actual offset of the amplifier. The MAX4238 and MAX4239 have typical offset drifts of $10\text{nV/}^\circ\text{C}$ and $50\text{nV}/1000$ hours.

Software-based offset adjustment: Zero calibration or tare measurements are examples of offset adjustment through software. The bridge's output is measured with the bridge in one state, no load on the cell, for example. Then the load is applied to the cell and another reading taken. The difference in the two readings is only due to the stimulus applied. Taking the difference in readings removes not only the offset of the electronics, but also the offset of the bridge. This is an extremely effective technique, but can only be used when the desired result is based on a change in the bridge's output. If an absolute reading of the bridge output is needed, this technique cannot be used.

Hardware/software offset adjustment: Adding a two-pole analog switch to the circuit allows a software calibration to be made in practically any application. In Figure 3, the switch is used to disconnect one side of the bridge from the amplifier and short the amplifier inputs together. Leaving the other side of the bridge connected to the input of the amplifier maintains the common-mode input voltage, thus eliminating any errors that might be caused by changes in common-mode voltage. Shorting the amplifier input allows a measurement of the system offset to be made. This reading is then subtracted from subsequent normal readings to remove the offset of all the electronics. Unfortunately this technique cannot remove the offset of the bridge.

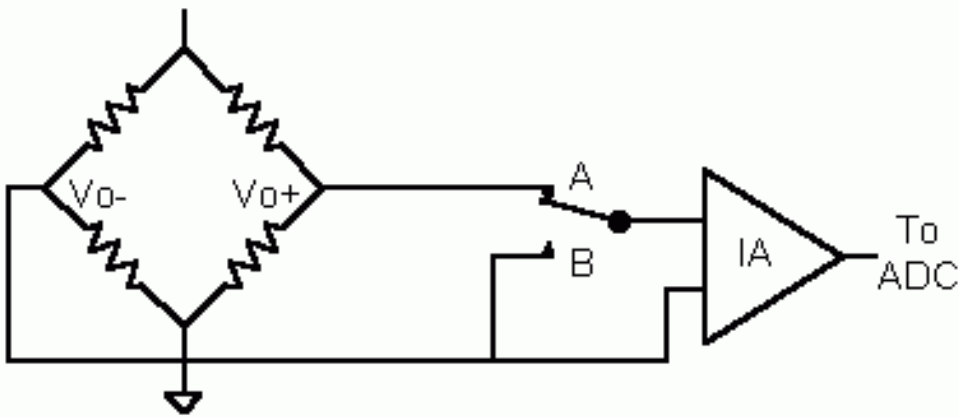

Figure 3. Adding a switch allows software calibration.

This type of automatic zero calibration is built into many modern ADCs and is extremely effective at removing ADC offsets. It does not, however, remove the offset of the bridge or the offset of any electronics between the bridge and the ADC.

A slightly more complicated form of offset correction uses a double-pole, double-throw switch between the bridge and the electronics (see Figure 4). Toggling the switch from positions A to position B reverses the polarity of the connection between the bridge and the amplifier. If the ADC reading taken when the switch is in position B is subtracted from the ADC reading taken when the switch is in position A, the result is $2 \cdot V_{0-} \cdot \text{Gain}$. There is no offset term. This technique not only eliminates the offset of electronics, but it also improves the signal-to-noise ratio by a factor of two.

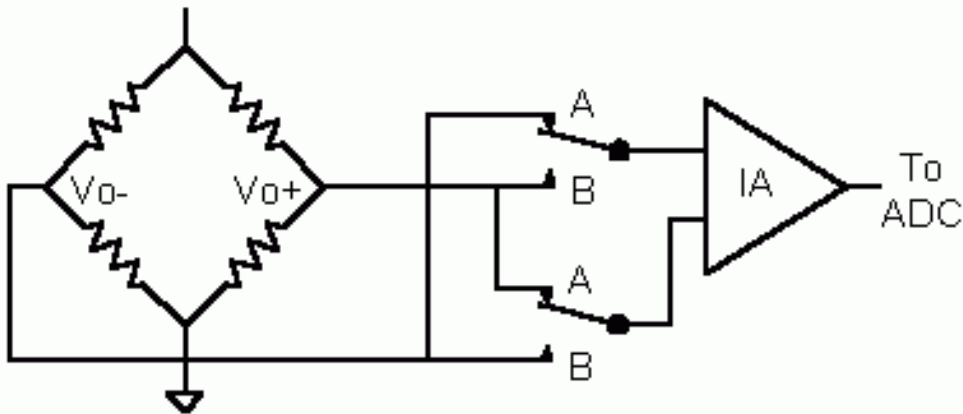

Figure 4. Illustration of adding a double-pole, double-throw switch for enhanced software calibration.

AC Bridge Excitation: While not used frequently today, for many years AC excitation of resistive bridges was a common and effective way to remove DC-offset errors in the electronics. If the bridge is driven with an AC voltage, the bridge's output will also be an AC signal. This signal can be capacitively coupled, amplified, level shifted, etc., and the AC amplitude of the final signal will be independent of the any DC offsets in the electronics. The amplitude of the AC signal is then measured using standard AC-measurement techniques. When AC excitation is used, it should be accomplished by minimizing changes in the common-mode voltage of the bridge. This greatly eases the common-mode rejection requirements of the circuit.

Noise

As mentioned above, noise is one of the biggest concerns in dealing with low output bridges. Moreover, the low-frequency nature of many bridge applications means that "flicker" or $1/F$ noise

must also be considered. A detailed discussion of noise is well beyond the scope of this article, and there are already many articles written on the subject. It is sufficient to say here that four sources of noise reduction should be considered in any good design.

1. Keeping noise out of the system (proper grounding, shielding, and wiring techniques)
2. Reducing noise generated in the system (architecture, component selection, and bias levels)
3. Reducing electronic noise (analog filters, common-mode rejection)
4. Software compensation or DSP (algorithms that use multiple measurements to enhance the wanted signal and reject unwanted signals)

The high-resolution sigma-delta converters developed in recent years greatly simplified the task of digitizing bridge signals. The next section will show how these converters address the five noise concerns discussed above.

High-Resolution Sigma-Delta Converters (ADCs)

Today's 24- and 16-bit sigma-delta ADCs with low-noise PGAs are nearly an ideal solution for measuring resistive bridges in low-speed applications. They address the five major problems (see discussion above, Figures 2 and following) of trying to digitize the analog output of a bridge.

Changes in Excitation Voltage, V_e

Buffered reference voltage inputs simplify the task of building a ratiometric system. A resistor-divider and a noise-suppression capacitor are the only components needed to create a reference voltage that tracks V_e . (See figure 2.) In a ratiometric system the output is insensitive to small variations in V_e , and the need for a high-accuracy voltage reference is eliminated.

If a ratiometric system is not an option, these multichannel ADCs are an alternate solution. One ADC channel can be used to measure the output of the bridge and a second input channel can be used to measure the bridge's excitation voltage. Equation 7 above can then be used to correct for variations in V_e .

Common-Mode Voltage

If the bridge and the ADC are powered by the same supply, then the bridge output will be a differential signal at $1/2V_{DD}$. These input conditions are ideal for most high-resolution sigma-delta converters. In addition, their excellent common-mode rejection (100+ dB) eliminates concerns about small common-mode voltage changes.

Offset Voltage

With voltage resolution in the sub- μV range, the bridge output can be connected directly to the ADC input. Assuming there are no thermocouple effects, the only source of offset error is the ADC itself. To reduce offset error, most of these converters have internal switches that allow them to apply zero volts to the input and take a measurement. This measurement can then be subtracted from subsequent bridge measurements to remove any offset in the ADC. Many ADCs perform this zero calibration automatically; in other cases the user must intentionally correct for the ADC offset. This method of offset correction reduces offset errors to the noise level of the ADC, which can be less than $1\mu\text{V}_{\text{P-P}}$.

Offset Drift

Using zero calibration on the ADC continually or frequently enough that the temperature cannot change significantly between calibration cycles, effectively eliminates any changes in offset due to temperature change or long-term drift. It should be noted that variations in the offset reading can equal the ADC peak-to-peak noise. If the goal is to detect small changes in the bridge output over a relatively short period of time, it may be best to turn off the auto calibration feature because this will eliminate one source of noise.

Noise

Noise is addressed in three ways, the most obvious of which is the internal digital filter. This filter practically eliminates the effects of high-frequency noise and can also provide rejection of lower frequency noise picked up from power lines. Normal mode rejection of power line frequencies is typically better than 100dB. The second form of noise reduction derives from high common-mode rejection, again typically greater than 100dB. Common-mode rejection reduces unwanted noise picked up by the bridge wires and reduces the effects of noise in the bridge's excitation voltage. Finally, continual zero calibration reduces flicker or 1/F noise at frequencies below the calibration update rate.

Inexpensive Tricks

Connecting the bridge's output directly to the input of a high-resolution sigma-delta ADC is not the solution to every problem. In some applications signal conditioning is needed to match the bridge's output to the input of the ADC being used. This signal conditioning falls into one of the three general categories: amplification, level shifting, and differential-to-single-ended conversion. A good instrumentation amplifier will accomplish all of these tasks, but may be expensive and could still be lacking in the concern about offset drift. The following circuits may provide adequate signal conditioning at a lower cost than an instrumentation amplifier.

Single Op Amp

If amplification is the only thing needed, then the simple circuit shown in Figure 5 may work. At first glance it looks like a poor choice, because it is not balanced and places a load on the bridge. However, loading the bridge (while not desirable) is not necessarily a problem. Many bridges are low impedance; 350 Ω is quite common. The impedance of each output will be half of that, or 150 Ω . This 150 Ω of resistance lowers the gain slightly by adding to the resistance of R1. Compensating for this additional resistance is easily done by choosing a value for R1 that is 150 Ω lower. There will, of course, be some tolerance in the 150 Ω value and the temperature coefficient of the resistance (TCR) of the bridge may not precisely match the TCR of R1 and R2. Nonetheless, if R1 is much larger than 150 Ω , these effects will be quite small. A switch for zero calibration has also been included in Figure 5.

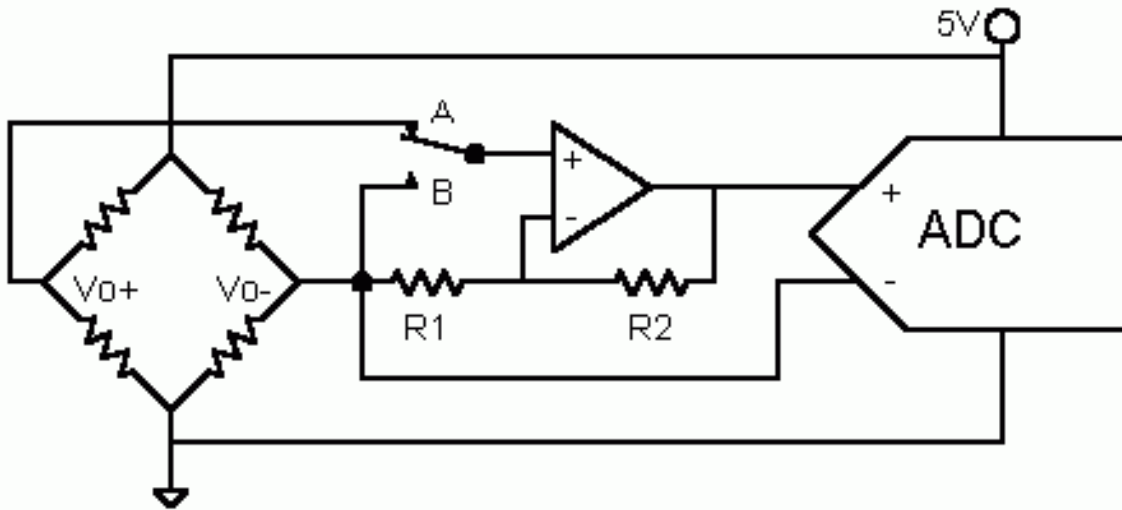

Figure 5. Example of interfacing to a low-impedance bridge.

Differential VS Instrumentation

For many applications, a differential amplifier can be used in place of an instrumentation amplifier. This not only lowers the cost, but it also lowers the number of noise sources and the sources for offset drift. As with the amplifier above, the value and TRC of the bridge resistors must be taken into account.

Dual Supply

The circuit in Figure 6 is worth mentioning because of its simplicity. The bridge output is amplified, level shifted, and converted to a ground referenced signal using only two op amps and two resistors. In addition, this circuit doubles the voltage across the bridge, which doubles the output signal. There is, however, a disadvantage to this approach—it requires a negative supply and it produces a slightly nonlinear output when using a fully active bridge. For bridges with active elements on only one side, this linearity error can be avoided by using the passive side of the bridge in the feedback loop that generates $-V_e$.

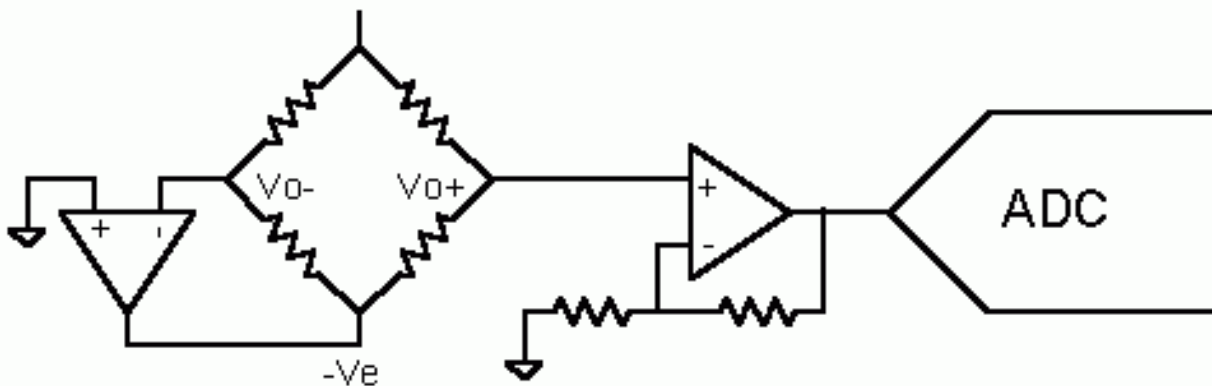

Figure 6. Illustration of an alternative circuit for interfacing to a low-impedance bridge.

Conclusions

Resistive bridges are still highly valuable for detecting small changes in resistance and for rejecting the resistance changes from unwanted sources. Modern analog-to-digital converters (ADCs) greatly simplify the task of measuring bridges. Adding one of these ADCs helps address the major concerns

of bridge circuits by integrating key features in the ADC such as: differential inputs, internal amplifiers, automatic zero calibration, high common-mode rejection, and digital noise filtering.